

### GENERAL DESCRIPTION



The working principle of ILT-110series inductive linear position sensors depends on the RLC coupling between the positioning element and the sensor. An output signal is provided according to the position of the positioning element. Thanks to the touchless working principle, they are long-lasting since there are no factors such as wear and tear.

They offer wide temperature tolerance, high repeatability, resolution and linearity. They work stably for a long time without being affected by electromagnetic fields. They are used in applications such as manufacturing engineering, plastic injection molding, textile, packaging, sheet metal working, woodwork, automation technology.

### WARNINGS

- The installation of the product is carried out by the customer who purchases the product, according to the wiring diagrams, installation information, etc. in this manual.
- Maintenance and repair should be done by the technicians authorized by the manufacturer firm.
- There must be minimum distance between the sensor and control unit. Avoid additions except the suitable connector unless it needs.
- The system may perform uncontrolled movements during start-up, especially when it is part of a control system whose parameters have not yet been set. For this reason, the sensor should not be used especially in applications where the safety of property and life depends on the operation of the device.
- For not to damage the sensor, supply directions and voltage range must be paid attention. Don't energize before all connections completed.
- Transducer and controller must be connected by using a shielded cable. The cable shield must be grounded.
- Elongation of the cable connection to more than 30 m results in loss of CE compliance!
- Very strong magnetic fields in the immediate vicinity of the position marker can cause false signals.
- Transport and storage should be at their original packaging and an ambient temperature of  $-20^{\circ}\text{C}/+70^{\circ}\text{C}$  in such a way that they will not be exposed to dust, humidity, impact, vibration, falling or water.
- Chemicals such as alcohol, thinner etc. should not be used for cleaning the product. The product should be wiped with a damp cloth.
- The product may be damaged and may become unusable if used outside of the specifications in the user manual.
- The product will be out of warranty if used outside of the specifications in the user manual and opened or repaired other than authorized services.

### TECHNICAL DATA

| Mechanical Data                     |  |
|-------------------------------------|--|
| <b>Housing Length (A)</b>           | B +84 mm   |
| <b>Electrical Stroke (B)</b>        | Between 100 mm...500 mm in steps of 50 mm<br>Between 500 mm...1000 mm in steps of 100 mm               |
| <b>Protection Class</b>             | IP64   |
| <b>Life</b>                         | Mechanically unlimited   |
| <b>Mechanical Fixing</b>            | Adjustable (movable) mounting feet   |
| <b>Operating Temperature</b>        | $-20^{\circ}\text{C} \dots +70^{\circ}\text{C}$  |
| <b>Storage Temperature</b>          | $-20^{\circ}\text{C} \dots +70^{\circ}\text{C}$  |
| <b>Material</b>                     | Position Marker: POM<br>Housing: Anodized aluminum   |
| Electrical Data                     |  |
| <b>Electrical stroke (B)</b>        | Between 100 mm...500 mm in steps of 50 mm, Between 500 mm...1000 mm in steps of 100 mm                 |
| <b>Protocol</b>                     | SSI 24 and 25 bit (ask for others)   |
| <b>Parity Bit</b>                   | Even / Odd / None (default)  |
| <b>Alarm Bit</b>                    | Active High / Active Low / None (default)  |
| <b>Process data area</b>            | Bit 0...Bit 19   |
| <b>Inputs</b>                       | RS422  |
| <b>Monofloptime (tm)</b>            | 20 $\mu\text{s}$   |
| <b>Encoding</b>                     | Gray, Binary   |
| <b>Output Update rate</b>           | 500 Hz (depends on the filter)   |
| <b>Resolution (LSB)</b>             | Selectable between 1...1000 $\mu\text{m}$  |
| <b>Signal propagation delay</b>     | 2, 3, 4, 5, 6, 8, 10 ms (according to filter selection)  |
| <b>Reproducibility</b>              | $< \pm 0.012 \text{ FS}$ (when the signal propagation delay is 10 ms)                                  |
| <b>Absolute Linearity</b>           | $\leq \pm 0.025 \text{ FS}$ (min. $\pm 100 \mu\text{m}$ ) (when the signal propagation delay is 10 ms) |
| <b>Supply voltage</b>               | 8...33 VDC   |
| <b>Supply voltage ripple</b>        | $\leq 10 \text{ Vss}$  |
| <b>Power consumption (w/o load)</b> | 0.5W   |
| <b>Overvoltage protection</b>       | 33 VDC   |
| <b>Reverse polarity protection</b>  | Yes, up to supply voltage max  |
| <b>Short circuit protection</b>     | Yes (outputs, GND and supply voltage up to 7V)   |
| <b>Ohmic load at outputs</b>        | $> 120 \Omega$   |
| <b>Max. Clockrate</b>               | 1 MHz  |

## SSI TIMING DIAGRAM

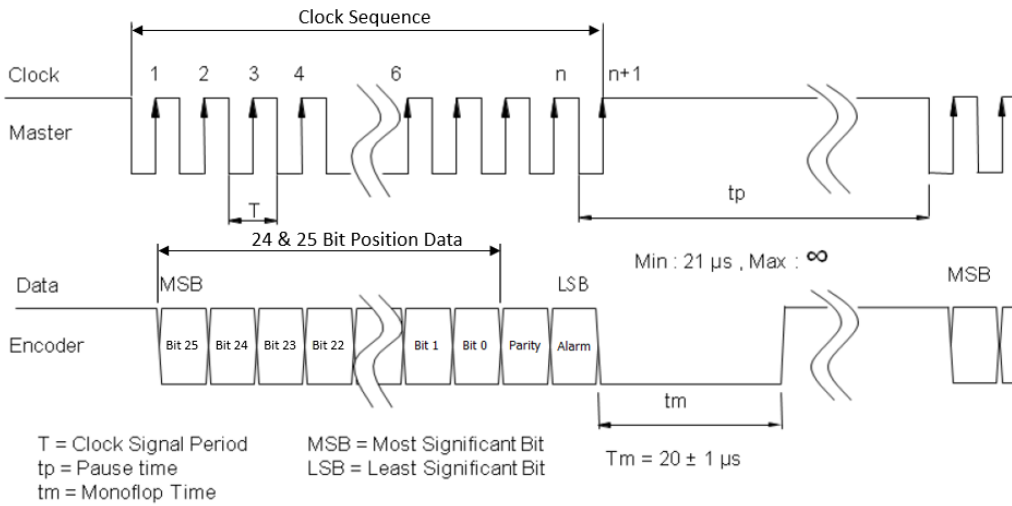

If the device resolution is less than 24 or 25 Bits, the remaining bit fields from the MSB are filled with 0.  
 The device indicates this status with the Alarm bit at power-on after the lock state.

Alarm: 1 (alarm)      MCU lock up alarm    MCU watchdog alarm  
 0 (no alarm)

## ELECTRICAL CONNECTIONS

| Signal         | Cable  | M12 / 8 pin male connector |
|----------------|--------|----------------------------|
| Clk+           | White  | Pin 1                      |
| Data+          | Yellow | Pin 2                      |
| Clk-           | Blue   | Pin 3                      |
| N/C            | N/C    | Pin 4                      |
| Data-          | Green  | Pin 5                      |
| GND            | Black  | Pin 6                      |
| Supply Voltage | Red    | Pin 7                      |
| N/C            | N/C    | Pin 8                      |

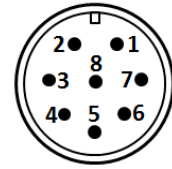

## MECHANICAL DIMENSIONS (mm) AND MOUNTING

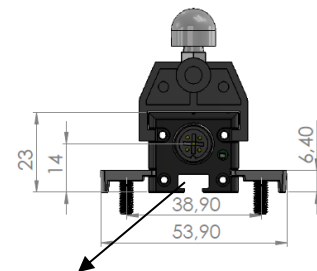
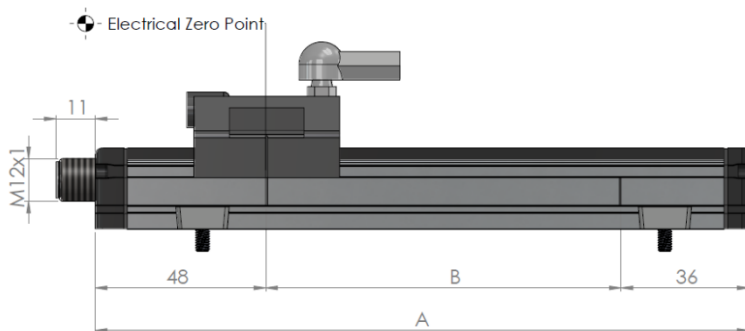

As an alternative to the mounting with mounting clamps the transducers can be fixed by a M8 nut (DIN 439, 4.0 mm thick) which is inserted into the groove.

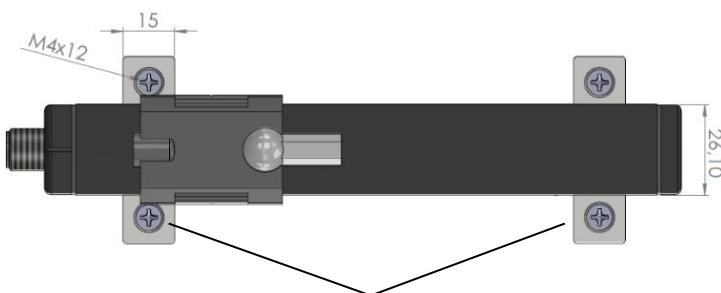

Mounting clamps:

- Do not attach to the flanges solely to the housing profile
- Several mounting clamps: position at an even distance
- 2 mounting clamps: distance to each other approx 2/3 of the housing length

# POSITION MARKERS

## GPM-U (Guided and Top Joint)

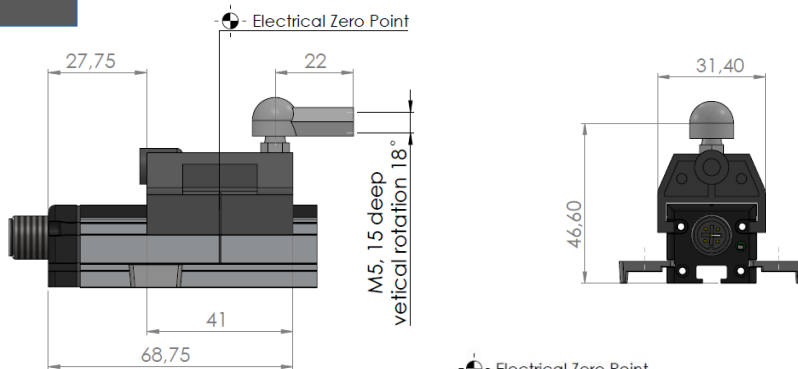

|                 | GPM-6-U                       | GPM-10-U       |
|-----------------|-------------------------------|----------------|
| Stroke Used     | 100 ...600 mm                 | 700 ...1000 mm |
| HousingMaterial | POM                           |                |
| Joint Material  | lgumid G / iglide®L280 (W300) |                |
| Weight          | ~20 gr                        |                |

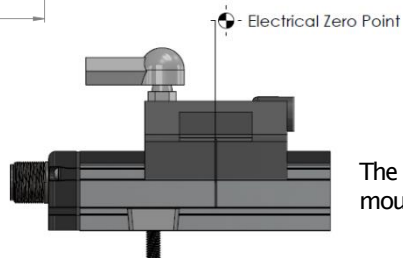

The position marker can be mounted in both directions.

## GPM-Y (Guided and Side Joint)

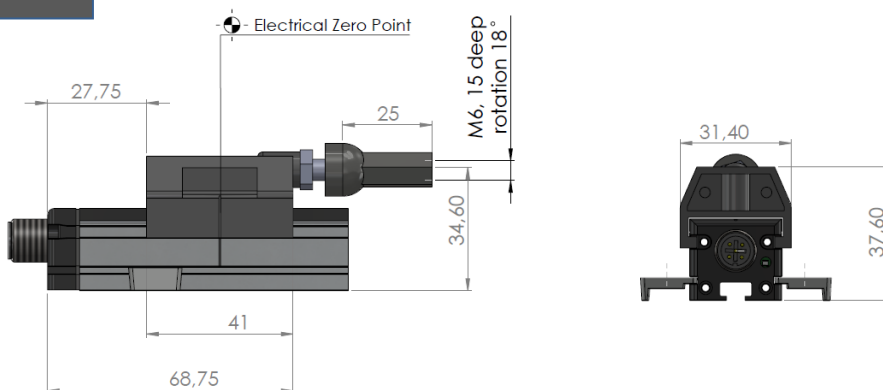

|                 | GPM-6-Y                       | GPM-10-Y       |
|-----------------|-------------------------------|----------------|
| Stroke Used     | 100 ...600 mm                 | 700 ...1000 mm |
| HousingMaterial | POM                           |                |
| Joint Material  | lgumid G / iglide®L280 (W300) |                |
| Weight          | ~22 gr                        |                |

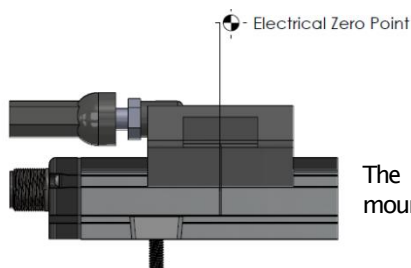

The position marker can be mounted in both directions.

## FPM (Floating and independent)

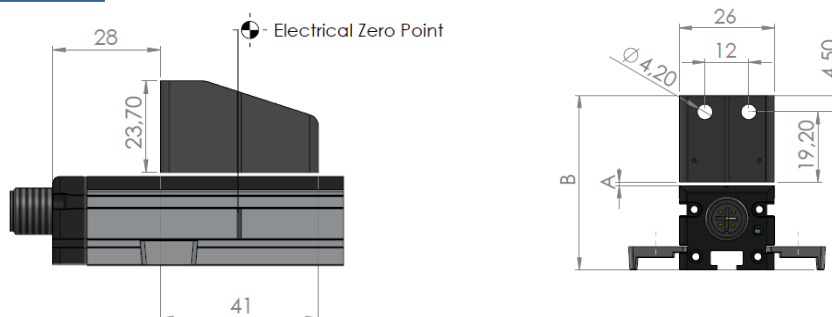

|                        | FPM-6         | FPM-10         |
|------------------------|---------------|----------------|
| Stroke Used            | 100 ...600 mm | 700 ...1000 mm |
| Working Distance (A)   | 0,3 mm        |                |
| Mounting Dimension (B) | 47 mm         |                |
| Perm. Lateral offset   | ±0,5 mm       |                |
| HousingMaterial        | POM           |                |
| Weight                 | ~23 gr        |                |

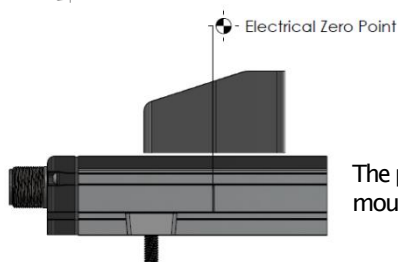

The position marker can be mounted in both directions.

## LED FUNCTION

| Led Color               | Description  |
|-------------------------|--|
| Off                     | Sensor is not working – No supply  |
| Green                   | Sensor is working – Position marker is within measuring range                            |
| Blue flash (1 sn)       | Sensor is working –Position marker is outside od measuring range ( $\pm 6\text{mmmax}$ ) |
| Red flash (1 sn)        | Sensor is working –Position marker is outside od measuring range                         |
| Red fast flash (100 ms) | Sensor error   |

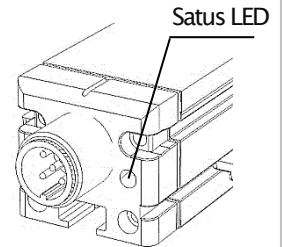

## BOX CONTENT

| Product         | Description  |
|-----------------|--|
| ILT-110         | Inductive Linear Position Sensor                                 |
| Mounting Clamps | 4 pcs up to 500 mm stroke, 6 pcs after 500 mm stroke             |
| Mounting Screw  | M4x15 countersunk screw (according to number of mounting clamps) |
| User Manual     | 1 pcs  |

## ORDER CODE

| Model   | Resolution                                |  | Electrical Interface |  | Parity Bit                             |  | Electrical Connection          |     |   |   |   |   |   |      |
|---|---|--|----------------------|--|--|--|--------------------------------|-----|---|---|---|---|---|------|
|   | Selectable between 1...1000 $\mu\text{m}$ |  | SSI : SSI            |  | E: Even<br>O: Odd<br>N: None (default) |  | S14M : M12/8pin male connector |     |   |   |   |   |   |      |
| ILT110  | -   | XXXX   | -                    | XXXX   | -                                      | XX   | -                              | XXX | - | X | - | X | - | XXXX |
| <b>Measuring Lengths (stroke)</b>   |   | <b>Filter Selection</b>  |                      | <b>Output Signal</b>   |  | <b>Alarm Bit</b>                                     |                                |     |   |   |   |   |   |      |
| Different measuring lengths from 100 mm to 1000 mm  |   | O2 : 2ms (standard)  |                      | 24G: SSI 24 bit, Gray<br>25G: SSI 25 bit, Gray<br>24B: SSI 24 bit, Binary<br>25B: SSI 25 bit, Binary |  | H: Active high<br>L: Active low<br>N: None (default) |                                |     |   |   |   |   |   |      |
| *Measuring length can be selected between 100 mm...500 mm in 50 mm steps, between 500 mm...1000 mm in 100 mm steps. |   | *For others see Electrical specifications/signal propagation delay |                      | *Ask for others.   |  |  |                                |     |   |   |   |   |   |      |



**Disposal of Packagings:** Packaging materials consist of recyclable materials. For providing recycling, please dispose waste packaging to collecting points of authorized recycling facilities.

**Disposal of E-Waste:** This device is in conformity with WEEE Directive and consists of recyclable materials. This product should not be disposed with general waste for preventing negative effects on environment and human health. This product should be disposed to collecting points of authorized recycling facilities. Further information can be reached from authorized unit.



MEGATRON, s.r.o. Mrštíkova 16  
100 00 Praha 10, Tel.: +420 274 780 972  
info@megatron.cz, www.megatron.cz