

#### GENERAL DESCRIPTION



The working principle of ILT-110 series inductive linear position sensors depends on the RLC coupling between the positioning element and the sensor. An output signal is provided according to the position of the positioning element. Thanks to the touchless working principle, they are long-lasting since there are no factors such as wear and tear.

They offer wide temperature tolerance, high repeatability, resolution and linearity. They work stably for a long time without being affected by electromagnetic fields. They are used in applications such as manufacturing engineering, plastic injection molding, textile, packaging, sheet metal working, woodwork, automation technology.

#### WARNINGS

- The installation of the product is carried out by the customer who purchases the product, according to the wiring diagrams, installation information, etc. in this manual.
- Maintenance and repair should be done by the technicians authorized by the manufacturer firm.
- There must be minimum distance between the sensor and control unit. Avoid additions except the suitable connector unless it needs.
- The system may perform uncontrolled movements during start-up, especially when it is part of a control system whose parameters have not yet been set. For this reason, the sensor should not be used especially in applications where the safety of property and life depends on the operation of the device.
- For not to damage the sensor, supply directions and voltage range must be paid attention. Don't energize before all connections completed.
- Transducer and controller must be connected by using a shielded cable. The cable shield must be grounded.
- Elongation of the cable connection to more than 30 m results in loss of CE compliance!
- Very strong magnetic fields in the immediate vicinity of the position marker can cause false signals.
- Transport and storage should be at their original packaging and an ambient temperature of  $-20^{\circ}\text{C} / +70^{\circ}\text{C}$  in such a way that they will not be exposed to dust, humidity, impact, vibration, falling or water.
- Chemicals such as alcohol, thinner etc. should not be used for cleaning the product. The product should be wiped with a damp cloth.
- The product may be damaged and may become unusable if used outside of the specifications in the user manual.
- The product will be out of warranty if used outside of the specifications in the user manual and opened or repaired other than authorized services.

#### TECHNICAL DATA

Mechanical Data	
<b>Housing Length (A)</b>	B +84 mm
<b>Electrical Stroke (B)</b>	Between 100 mm...500mm in steps of 50 mm Between 500 mm...1000mm in steps of 100 mm
<b>Protection Class</b>	IP64
<b>Life</b>	Mechanically unlimited
<b>Mechanical Fixing</b>	Adjustable (movable) mounting feet
<b>Operating Temperature</b>	$-20^{\circ}\text{C} \dots +70^{\circ}\text{C}$
<b>Storage Temperature</b>	$-20^{\circ}\text{C} \dots +70^{\circ}\text{C}$
<b>Material</b>	Position Marker: POM Housing: Anodized aluminum
Electrical Data	
<b>Electrical stroke (B)</b>	Between 100 mm...500 mm in steps of 50 mm, Between 500 mm...1000 mm in steps of 100 mm
<b>Output Signal</b>	0-10V, 0.5-4.5V, 0-5V, 0-20mA, 4-20mA
<b>Number of channel</b>	1
<b>Output Update rate</b>	500 Hz max.
<b>Signal propagation delay</b>	2, 3, 4, 5, 6, 8, 10 ms (according to filter selection)
<b>Resolution</b>	16 bit
<b>Absolute Linearity</b>	$\leq \pm 0.025$ FS (min. $\pm 100 \mu\text{m}$ ) (when the signal propagation delay is 10 ms)
<b>Reproducibility</b>	$< \pm 0.012$ FS (when the signal propagation delay is 10 ms)
<b>Supply voltage</b>	15...33VDC
<b>Supply voltage ripple</b>	$\leq 10$ Vss
<b>Power consumption (w/o load)</b>	0.5W
<b>Overvoltage protection</b>	33 VDC
<b>Reverse polarity protection</b>	Yes, up to supply voltage max
<b>Short circuit protection</b>	Yes (outputs, GND and supply voltage), Up to 12V

## ELECTRICAL CONNECTIONS

M12/5 Pin male conn. On the sensor

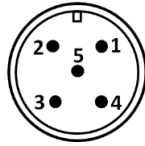

Extension cable with M12/5 pin female conn.

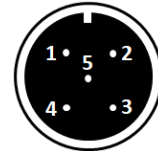

Analog Voltage	Analog Current	Pin No	Cable Color	Pin No	Cable Color
+V	+V	1	Red	1	Brown
N/C	Iout	2	Green	2	White
GND	GND	3	Black	3	Blue
Vout	N/C	4	Yellow	4	Black
Prog	Prog	5	Pink	5	Grey

### Analog Output Settings

Blue or green LED flashes every second in normal operating condition.

Prog pin (pin 5) and GND (pin 3) are short-circuited until the LED on the product starts to flash blue. Thus, programming mode is entered.

**Step 1 – Setting the starting point:** After the position marker is brought to the desired starting point, Prog pin (pin 5) and GND (pin 3) are short-circuited for 1 second and the minimum analog value (4mA/0V) is set. In this case, the LED lights up blue for 2 seconds and then proceed to step 2.

**Step 2 – Setting the end point:** After the position marker is brought to the desired end point, Prog pin (pin 5) and GND (pin 3) are short-circuited for 1 second. Thus, the max analog value (20mA / 10V) is set and the programming mode is exited.

### Return to Factory Settings:

In step 1, if Prog pin (pin 5) and GND (pin 3) are short-circuited until the LED on the product starts to flash green, the factory settings will be restored (starting 4mA / 0V, ending 20mA / 10V).

In step 2, if Prog pin (pin 5) and GND (pin 3) are short-circuited until the LED on the product starts to flash green, the factory settings will be restored (start 20mA / 10V, end 4mA / 0V).

**Note:** After the analog output settings are finished, the Prog pin must be left connected to +V.

## MECHANICAL DIMENSIONS (mm) AND MOUNTING

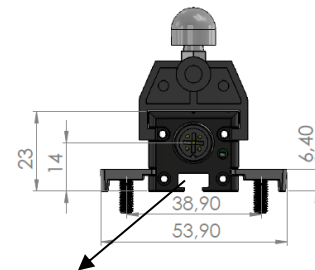
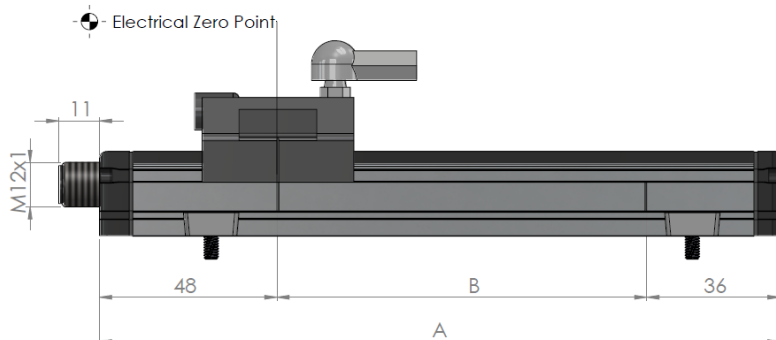

As an alternative to the mounting with mounting clamps the transducers can be fixed by a M8 nut (DIN 439, 4.0 mm thick) which is inserted into the groove.

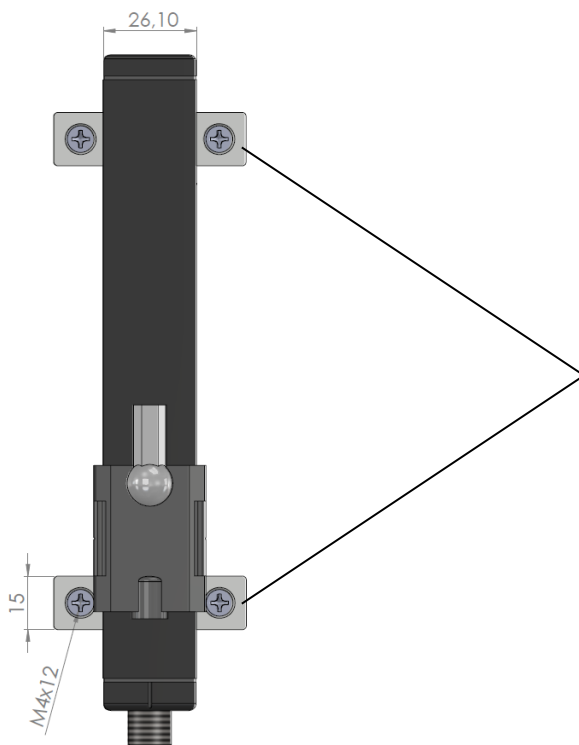

### Mounting clamps:

- Do not attach to the flanges solely to the housing profile
- Several mounting clamps : position at an even distance
- 2 mounting clamps : distance to each other approx 2/3 of the housing length

# POSITION MARKERS

## GPM-U (Guided and Top Joint)

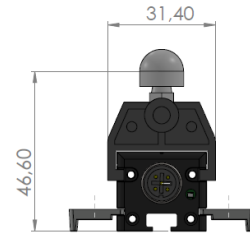
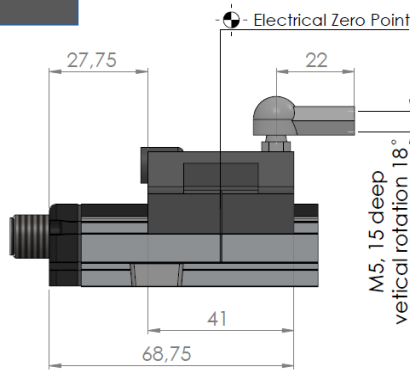

	GPM-6-U	GPM-10-U
Stroke Used	100 ... 600 mm	700 ... 1000 mm
Housing Material	POM	
Joint Material	Igurid G / iglide®L280 (W300)	
Weight	~20 gr	

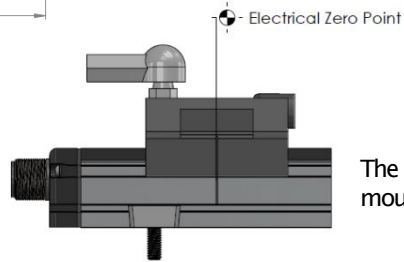

The position marker can be mounted in both directions.

## GPM-Y (Guided and Side Joint)

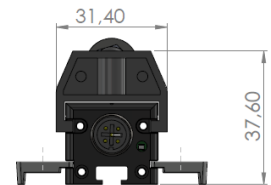
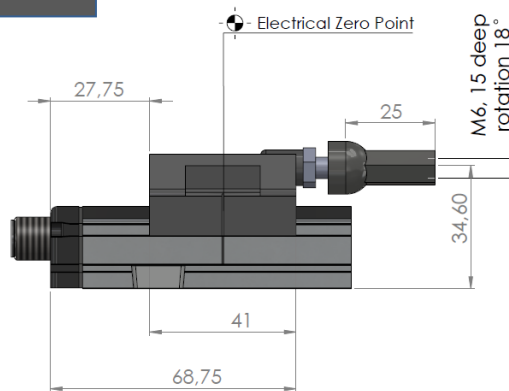

	GPM-6-Y	GPM-10-Y
Stroke Used	100 ... 600 mm	700 ... 1000 mm
Housing Material	POM	
Joint Material	Igurid G / iglide®L280 (W300)	
Weight	~22 gr	

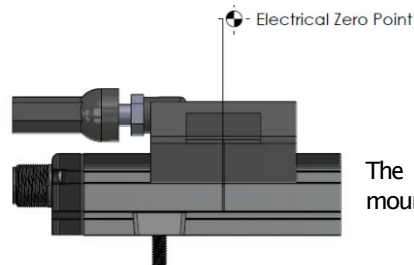

The position marker can be mounted in both directions.

## FPM (Floating and independent)

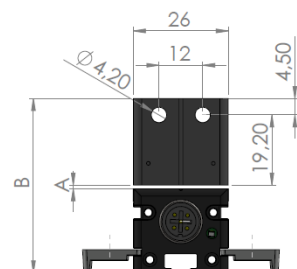
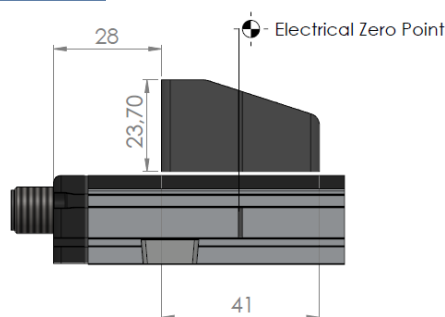

	FPM-6	FPM-10
Stroke Used	100 ... 600 mm	700 ... 1000 mm
Working Distance (A)	0,3 mm	
Mounting Dimension (B)	47 mm	
Perm. Lateral offset	±0,5 mm	
Housing Material	POM	
Weight	~23 gr	

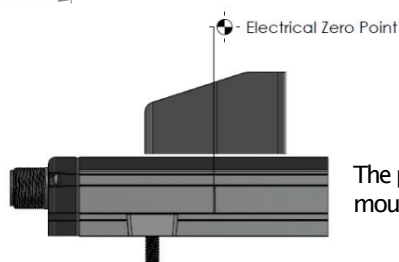

The position marker can be mounted in both directions.

## LED FUNCTION

Led Color	Description
Off	Sensor is not working – No supply
Green	Sensor is working – Position marker is within measuring range
Blue flash (1 sn)	Sensor is working –Position marker is outside od measuring range ( $\pm 6\text{mmmax}$ )
Red flash (1 sn)	Sensor is working –Position marker is outside od measuring range
Red fast flash (100 ms)	Sensor error

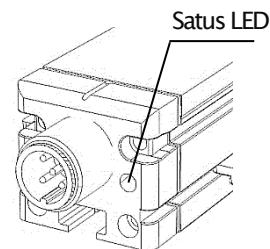

## BOX CONTENT

Product	Description
ILT-110	Inductive Linear Position Sensor
Mounting Clamps	4 pcs up to 500 mm stroke, 6 pcs after 500 mm stroke
Mounting Screw	M4x15 countersunk screw (according to number of mounting clamps)
User Manual	1 pcs

## ORDER CODE

### Model

ILT110 - XXXX - XX - XX - XXXX

### Filter Selection

O2 : 2ms (standard)

\*For others see  
Electrical specifications/signal  
propagation delay

### Electrical Connection

S69M : M12/5 pin male  
connector

### Measuring Lengths (stroke)



Different measuring lengths from 100 mm  
to 1000 mm

\*Measuring length can be selected between  
100 mm...500 mm in 50 mm steps, between  
500 mm...1000 mm in 100 mm steps.

### Electrical Interface

V: 0-10V  
V1: 0-5V  
V3: 0.5-4.5V  
A: 4-20 mA  
A0: 0-20 mA

## OPTIONAL PRODUCTS

Product	Code	Description	Pin Configuration
	M12/P5 CONNECTOR SMT 90°	M12/5 pin female connector, with 5 meters cable, 90° (For connection with M12/5 pin male connector on the sensor)	 <p>Pin1: Brown Pin2: White Pin3: Blue Pin4: Black Pin5: Grey</p>
	M12/P5 CONNECTOR SMT STRAIGHT	M12/5 pin female connector, with 5 meters cable, straight (For connection with M12/5 pin male connector on the sensor)	



**Disposal of Packagings:** Packaging materials consist of recyclable materials. For providing recycling, please dispose waste packaging to collecting points of authorized recycling facilities.

**Disposal of E-Waste:** This device is in conformity with WEEE Directive and consists of recyclable materials. This product should not be disposed with general waste for preventing negative effects on environment and human health. This product should be disposed to collecting points of authorized recycling facilities. Further information can be reached from authorized unit.



MEGATRON, s.r.o. Mrštíkova 16

100 00 Praha 10, Tel.: +420 274 780 972

info@megatron.cz, www.megatron.cz